

FOR MORE INFO CONTACT: American Crane & Equipment Corp. - Authorized Distributor
 Tel: 877-503-2972 Fax: 484-945-0430 Email: sales@americancrane.com Website: www.americancrane.com

- A 15 7/8"
- B 1 3/4"
- C 7 5/8"
- D 5"
- E 37 1/4"
- F 36"
- G 13 1/2"
- * H 1 1/8"
- * I 1 9/32"
- J 6 1/2"

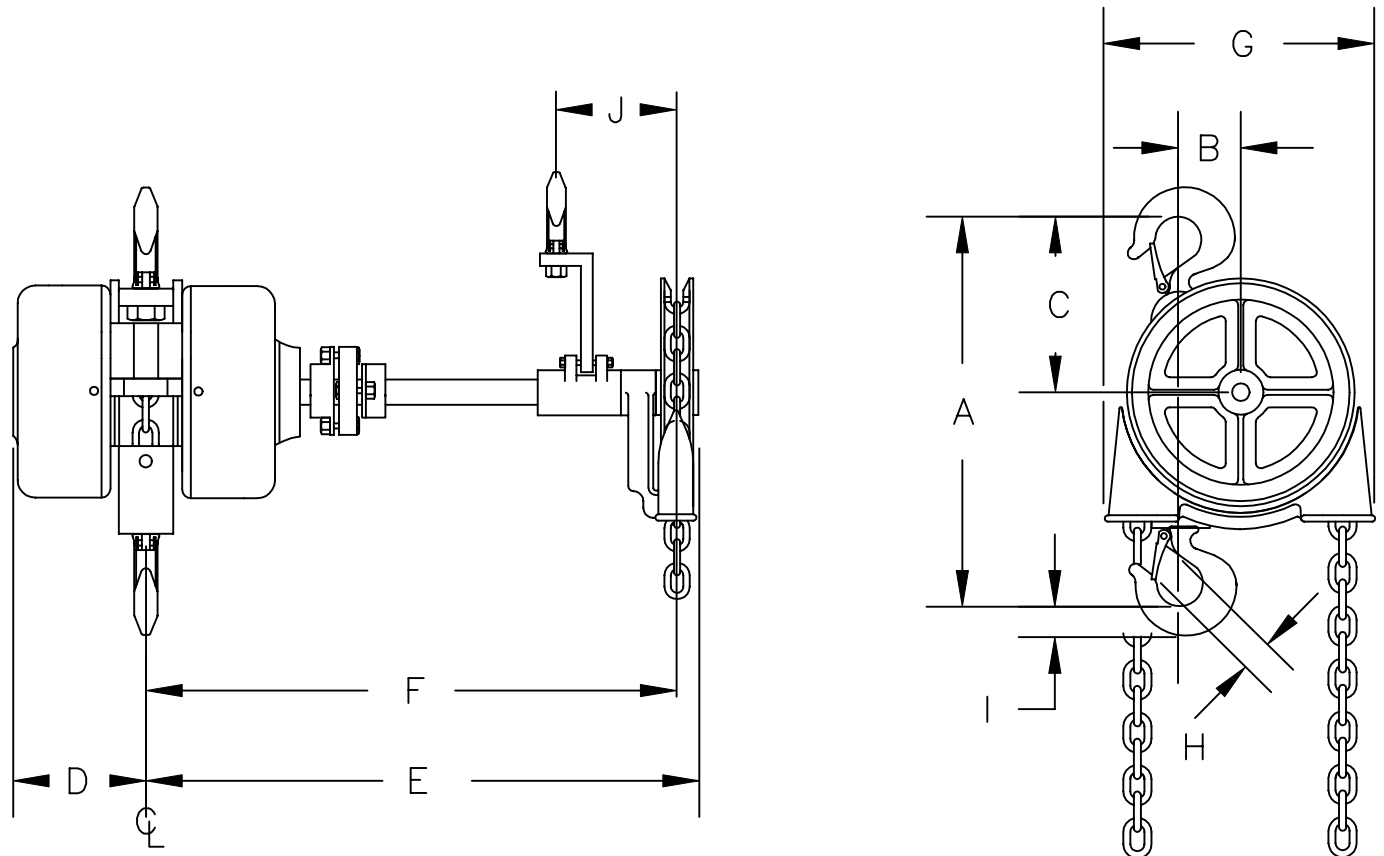

* DIM. FOR TOP & BOTTOM HOOK

1 1/2 - 2 TON
 EXTENDED HAND WHEEL HOIST

CHESTER HOIST
 LISBON, OHIO

DR. RLB	TR.	CK.	AP.
SCALE NONE		DATE 6-19-00	
REF. DWG. NO.		2EXTH	

Dwg. No. CD031

MK.	REVISIONS	CK-DATE
-----	-----------	---------